



Microswitch Configuration

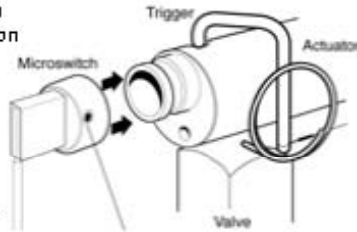
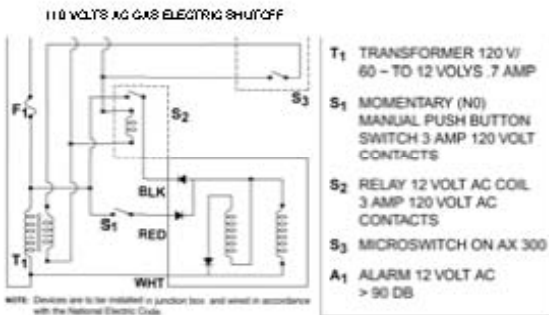
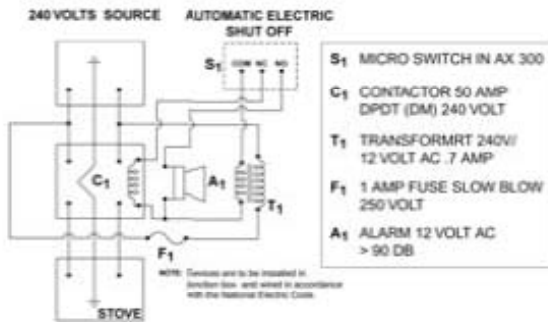

Figure V

SMARTX



Installation & Service Manual AX-300 Automatic Range-Top Fire Extinguisher

Patented

4,979,572

4,813,487

4,756,839

Patents Allowed

Patent Pending

SMARTX

P.O. Box 244710 Boynton Beach, FL 33424 (561) 243-1337
Fax (561) 244-5717 Email - 1@smarx.net Web - www.smarx.net

*SMARTX, flame logo and Acc-Ble TM are trademarks of SMARTX Inc.

SPECIFICATIONS

Model # AX-300

Automatically activated using fusible element rated at 160°F. - 212°F for electric stoves and 280°F. for gas stoves.

Operating pressure at 70°F is 100 PSI. Operating temperature range is 32°F - 120°F.

6 square feet (864 square inches) surface area protection. Range top area up to 36" x 24".

Smartx™ modular pre-engineered automatic liquid fire extinguisher system installs in minimum record time with adjustable spray nozzles.

Plug-in designed for non-skilled craftsman installation.

Contains non-toxic, non-corrosive liquid "Acu-Lite™" fire suppression agent (3 lbs. by weight).

Fast easy clean up after fire. Minimum recharge and installation cost.

Model # AX-300 is designed for residential, conventional range tops. the system is not designed to protect commercial cooking appliances, ranges incorporating char-broilers, rotisseries, attachments and the like.

* *Smartx flame logo and Acu-Lite™* are trademarks of Smartx, Inc.

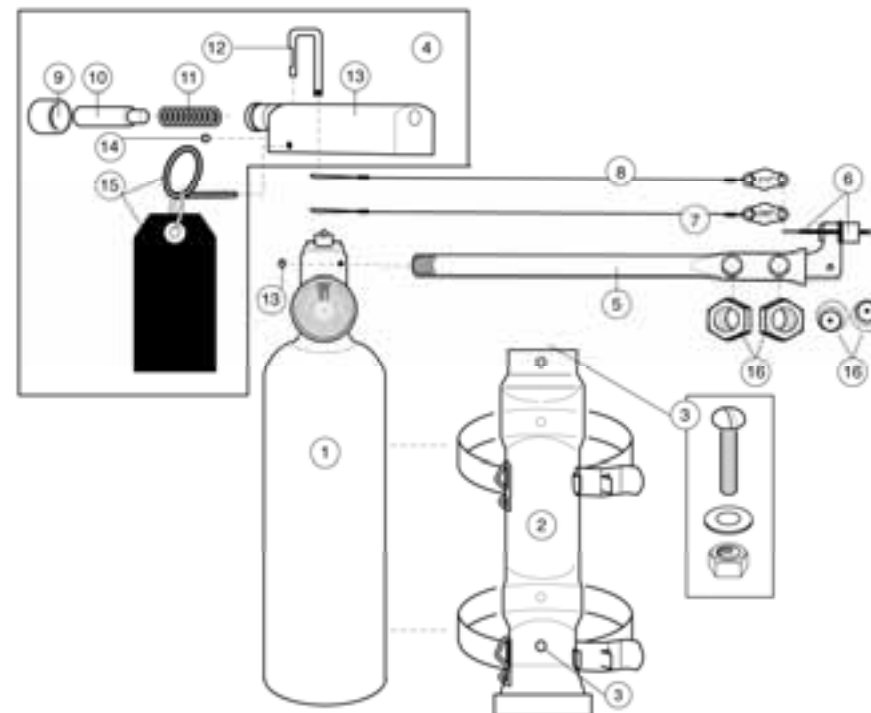

Modular Components Available: Components are Supplied by SmartX or other Manufacturers

Part #	Part Description
8883000	Microswitch for:
8884000	Automatic electric shut off
7774000	Automatic gas shut off
8885000	Audible alarm

Other options available:

5009912	Replacement Kit for AX-300, 3lb. Acu-Lite™, Cylinder Pressurized, Valve & part No. 5009212 fuse link (electric).
5009980	Replacement Kit for AX-300, 3lb. Acu-Lite™, Cylinder Pressurized, Valve & part No.5009280 fuse link (gas)

Total Weight, 7 lbs. Patented, Patents Allowed, Patents Pending

Parts List					
Item #	Part #	Description	Item #	Part #	Description
1	5009999	Cylinder AX-300 (3 lbs. Acu-Lite™ pressurized to 100 PSI) with gauge and valve assembly	9	3337700	Sensing Cap
2	100082C	Bracket bottom mount	10	3333500	Ram
3	3300310	3/16" diameter bolt - 1" long including washer & nut	11	3334400	Spring
4	5505530	Actuator assembly	12	3336600	Trigger
5	3300340	Pipe assembly with fuse retainer	13	3333300	Actuator Housing
6	5000010	Fuse retainer & nut	14	3332100	Set screw
7	5009280	Fuse link & cable assembly (gas)	15	9991500	Pull pin & warning tag
8	5009212	Fuse link & cable assembly (electric)	16	3300950	Nozzle Assembly (Nozzle & Nut)

Figure IV

Annual Inspection Procedure

1. Replace fuseable link only if required by authority having jurisdiction. Check to make sure actuator assembly is free and clear and not distorted.
2. Check that pressure gauge is in green zone or 100 PSIG and that face cover is not distorted.
3. Verify that nozzles are properly aimed with laser.

Replacement and Rearming Procedure

1. Discharged or depressurized units must be replaced and must not be recharged.
2. Remove the entire assembly from the brackets.
3. Release the cylinder and valve assembly by removing the set screw and unscrewing actuator assembly from valve. (See Figure III).
4. Immerse or flush the actuator housing, pipe, and nozzle assembly with significant amounts of water, to remove any residual chemical agent. Allow to dry.
5. **WARNING: Release of the actuator spring, while rearming, will project the actuator hammer with a very high velocity. DO NOT stand or position oneself in front of the actuator assembly while re-arming.**

Re-arm actuator assembly using screw driver and install fusible links (see Figure III).

- A) Secure the actuator and short piping apparatus in a vise or equivalent device as shown. (Do not put any clamping pressure on the mouth trigger end of the actuator).
 - B) Remove the sensing cap (if applicable) and apply pressure on the steel ram (about 50 lbs.) with a screwdriver having a 1/4" shank of 4" or more of length, so as to fully compress the spring. At this point, while maintaining pressure on ram, advance the trigger and loop the fusible link cable assembly over the slot in the trigger. Carefully remove the screwdriver.
 - C) Replace the sensing cap (if applicable).
6. **WARNING: Be sure protective packaging is removed from top of stem and valve Assembly. (See Figure III before attaching).**

Reattach the cylinder and valve assembly to the actuator housing by screwing valve into actuator housing and replacing nozzle pipe assembly and tightening both sets of screws. (See Figure III).

7. Return the discharged or depressurized cylinder and valve assembly for credit to Smartx
Discarded units should be disposed of with other metal refuse. Remove any remaining chemical agent or pressure from returned or discarded units. Flush any discarded chemical agent with significant amounts of water.
- 8) Replace the cylinder, valve assembly and "Acu-Lite™" chemical agent within a twelve (12) year period of time from the date stamped on the cylinder label.

Figure I

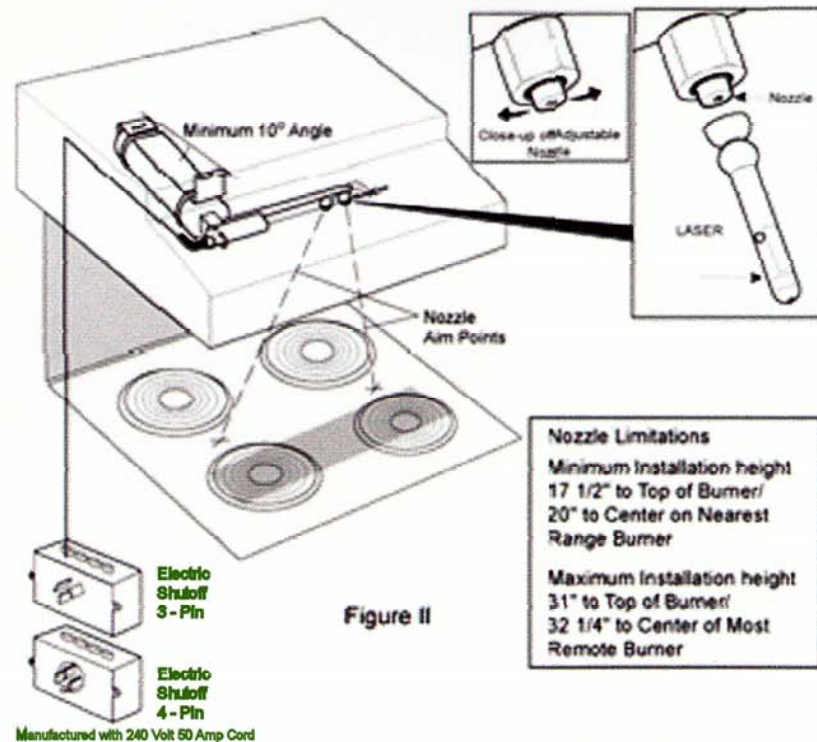
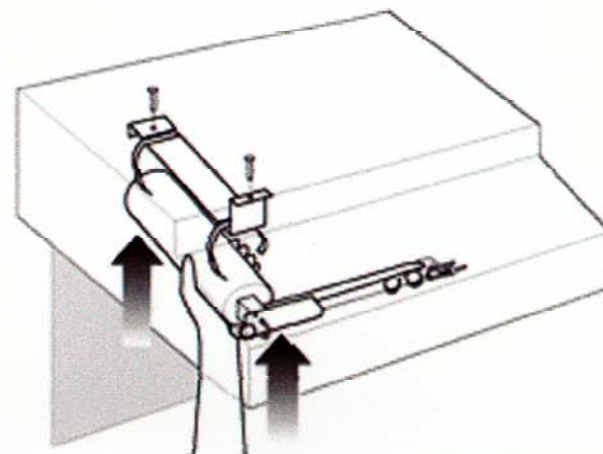

Nozzle Limitations
 Minimum Installation height
 17 1/2" to Top of Burner/
 20" to Center on Nearest
 Range Burner
 Maximum Installation height
 31" to Top of Burner/
 32 1/4" to Center of Most
 Remote Burner

Fusible Link Limitations
 Maximum vertical height from Center of
 Fusible Link to Top of a Range Burner
 is 31 3/4"/Minimum Height is 19"
 The Maximum Linear Distance from the Center of
 the Fusible Link to the Center of the Most Remote
 Range of Burner is 32"

Re-arming Actuator and Re-Installing New Fuse Link

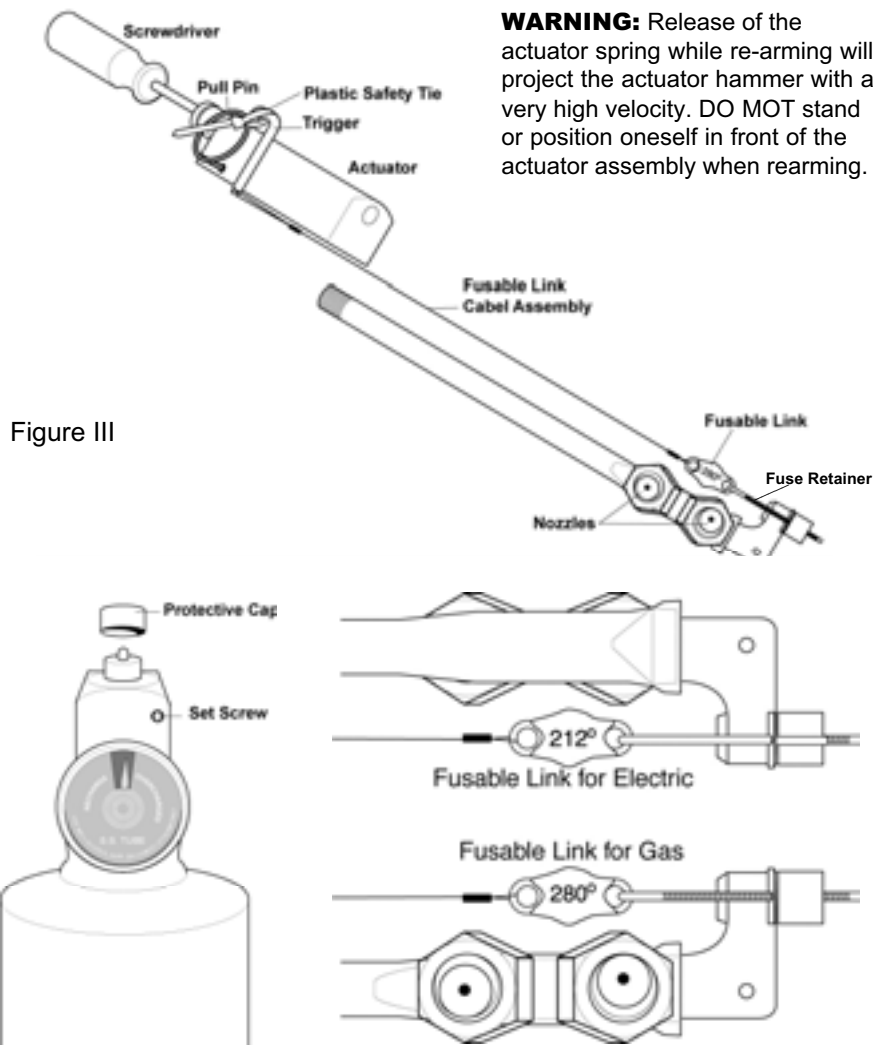

Figure III

"Acu-Lite™" Fire Suppressant Agent is not harmful to surface finishes, however, it may leave a dull film if not wiped with a damp sponge or washed with warm soapy water. It is a chemical agent that is non-toxic but can cause irritation. Avoid contact with eyes, skin and clothing or ingestion. Wash thoroughly after handling. Flush with large amounts of water for 15 minutes in case of contact. If swallowed DO NOT induce vomiting. Give large quantities of water. Seek medical attention immediately.

Installation Tools

Pencil or Marker • Screwdriver • Crescent Wrench

Hammer • Center Punch • Allen Wrench • 3/36" Drill

Installation Procedures

1. Remove entire assembly from protective packaging.
2. Attach pipe and nozzle assembly by threading, hand tight, into the 5/8" opening in the cylinder valve. Align the nozzles to face the center of the range top which is the same direction that the pressure gauge faces. (See Figure I and II). Tighten the allen head set screw in the valve housing to secure the pipe and nozzle assembly. (See Figure II).
3. Attach bracket to cylinder as shown; (See Figure I and II).
4. Place and hold the entire assembly in the vent hood and position so that the nozzles are approximately centered on the stove top. (See Figure I and II).
5. Mark the position of the bracket with a pencil for alignment procedures
6. Remove bracket from cylinder and bracket assembly. Replace bracket in aligned position as marked on the vent hood. Mark hole spacing position with a pencil.
7. Punch out holes with center punch. Drill out holes with 3/16" diameter drill.
8. Attach bracket with two 1" long bolts, washers and nuts. (See Figure II). Caution: Bracket is installed to have valve head assembly lower in front of hood. (Minimum 10" incline).
9. Place entire assembly in bracket with valve head forward and close spring clips on strap to secure. (See Figure II).
10. Nozzles on assembly must be the same distance from the top of the stove surface. (Parallel to range top).
11. Plug LASER into nozzle aim LASER plus or minus 1" from center of burners. (See figure II). Adjust by loosening 1" hex head nut and tighten hex nut at target X.
12. Loop fusible link wire over the groove in the actuator trigger and then attach the fusible link to the nozzle housing by inserting into the perforated slot on the housing. (See Figure III).
13. Prior to operation check pressure gauge to be 100 PSIG, no obstructions to fusible link and actuator assembly, nozzles are tightened and directed to within plus or minus 1" from center of range burners. Review the applicable requirements in NFPA 17A.
14. **The extinguisher is made operationable by removing the plastic seal and pull pin. (See Figure III).**
CAUTION: Extinguisher will activate unless fusible link wire is secure and tight.
15. Congratulations! You have completed the installation of the most modern automatic fire extinguisher system for home use.

ELECTRICAL CONNECTIONS: Automatic stove shut off equipment is required. Grease fires can reignite when electric or gas utilities energizing the range are not automatically disconnected. (See wiring diagrams on the back cover - Figure V).